

URGENT

MWO effective date 01 Nov 2001 and completion date 30 June 2006

MWO 9-2320-279-20-9

MODIFICATION WORK ORDER

MODIFICATION OF M977 SERIES 8X8 HEAVY EXPANDED MOBILITY TACTICAL TRUCK (HEMTT)

INSTALLATION INSTRUCTIONS FOR BOLT TOGETHER WHEELS

MODEL	NSN
TRUCK, CARGO, W/WINCH M977	2320-01-097-0260
TRUCK, CARGO, W/O WINCH M977	2320-01-099-6426
TRUCK, TANK, FUEL, W/WINCH M978	2320-01-097-0249
TRUCK, TANK, FUEL, W/O WINCH M978	2320-01-100-7672
TRUCK, TRACTOR, W/WINCH, W/O CRANE M983	2320-01-097-0247
TRUCK, WRECKER, W/WINCH M984	2320-01-097-0248
TRUCK, WRECKER, W/WINCH M984A1	2320-01-195-7641
TRUCK, CARGO, W/WINCH M985	2320-01-097-0261
TRUCK, CARGO, W/O WINCH M985	2320-01-100-7673
TRUCK, CARGO, W/WINCH M985E1	2320-01-194-7032
TRUCK, LHS, M1120	2320-01-471-1326
TRUCK, CBT, W/WINCH, M1977	2320-01-443-8023
TRUCK, CBT, W/O WINCH, M1977	2320-01-442-1940

**HEADQUARTERS, DEPARTMENT OF THE ARMY, WASHINGTON, DC
1 December 2001**

REPORTING ERRORS AND RECOMMENDING IMPROVEMENTS

You can help improve this publication. If you find any mistakes or if you know of a way to improve the procedures, please let us know. Submit your DA Form 2028 (Recommended Changes to Equipment Technical Publications), through the Internet, on the Army Electronic Product Support (AEPS) website. The Internet address is <http://aeps.ria.army.mil>. If you need a password, scroll down and click on "ACCESS REQUEST FORM". The DA Form 2028 is located in the ONLINE FORMS PROCESSING section of the AEPS. Fill out the form and click on SUBMIT. Using this form on the AEPS will enable us to respond quicker to your comments and better manage the DA Form 2028 program. You may also mail, fax or E-mail your letter or DA Form 2028 direct to: AMSTA-LC-CI / TECH PUBS, TACOM-RI, 1 Rock Island Arsenal, Rock Island, IL 61299-7630. The email address is TACOM-TECH-PUBS@ria.army.mil. The fax number is DSN 793-0726 or Commercial (309) 782-0726.

Approved for public release; distribution is unlimited

MWO 9-2320-279-20-9

1. PURPOSE Changing over the wheels on the HEMTT will reduce chances for accidents and injury when handling the current split ring wheel.

2. PRIORITY. This Modification is classified as URGENT.

3. END ITEM TO BE MODIFIED. Refer to table 1.

Table 1. End Items to be Modified

<u>Nomenclature</u>	<u>NSN</u>	<u>PN</u>	<u>CAGE</u>	<u>Model</u>
Truck, Cargo, w/Winch	2320-01-097-0260	XM977WW	19207	M977
Truck, Cargo w/o, Winch	2320-01-099-6426	XM977WOW	19207	M977
Truck, Tank, Fuel, w/Winch	2320-01-097-0249	XM978WW	19207	M978
Truck, Tank, Fuel, w/o Winch	2320-01-100-7672	XM978WOW	19207	M978
Truck, Tractor, w/Winch, w/o Crn	2320-01-097-0247	XM983WOC	19207	M983
Truck, Wrecker, w/Winch	2320-01-097-0248	XM984WW	19207	M984
Truck, Wrecker, w/Winch	2320-01-195-7641	XM984A1WW	19207	M984A1
Truck, Cargo, w/Winch	2320-01-097-0261	XM985WW	19207	M985
Truck, Cargo, w/o Winch	2320-01-100-7673	XM985WOW	19207	M985
Truck, Cargo w/Winch (GMT)	2320-01-194-7032	XM985E1WW	19207	M985E1
Truck, LHS	2320-01-471-1326	XM1120	19207	M1120
Truck, CBT, w/Winch	2320-01-443-8023	M1977	19207	M1977
Truck, CBT, w/o Winch	2320-01-442-1940	HEMTTCBT	19207	M1977

4. MODULE (COMPONENTS, ASSEMBLIES, SUBASSEMBLIES, BOARDS AND CARDS) TO BE MODIFIED. Not applicable.

5. PARTS TO BE MODIFIED. SEE TABLE 2

Table 2. Parts to be Modified

<u>Nomenclature</u>	<u>NSN</u>	<u>PN</u>	<u>CAGE</u>
Tire, Pneumatic	2610-01-334-2694	16.00R20/XZLTLMR	0A8K5
Tire, Pneumatic	2610-01-126-1576	16.00R20/J/TBTR	81348
Inner tube, Pneumatic	2610-01-165-0567	20V576	12195
Flap, Inner Tube, Pneumatic	2640-01-176-4797	15-20	12195
Ring, Lock, Automotive	2530-00-278-6567	41857-2	09386
Ring, Side Automotive	2530-01-151-5579	41856-12	09386
Wheel, Pneumatic Tire	2530-01-159-9804	1307030	45152

6. APPLICATION.

a. Time compliance Schedule: The effective date is 1 November 2001 and completion date is 30 June 2006.

b. Lowest Level of Maintenance Authorized to Apply the MWO: Unit

c. Work Force Man-Hour Requirements for Application of this MWO to a single Unit, End Item or System is as follows:

<u>Requirements</u>	<u>MAN-HOURS</u>
WORK FORCE/SKILLS	
Heavy Wheeled Vehicle Mechanic (MOS 63S)(2)	
Removal and replacement	5.5
Disassembly and demilitarization	9

7. TECHNICAL PUBLICATIONS AFFECTED/CHANGED. Refer to Table 3.

Table 3. Publications Affected

<u>Publication</u>	<u>Date</u>
TM 9-2320-279-10-1	November 1996
TM 9-2320-279-20-2	April 1987

8. MWO KITS/PARTS AND THEIR DISPOSITION

- a. Kits/Parts Needed to apply this MWO
 - (1) The parts listed in Table 4 are required to accomplish this MWO

Table 4. Part and Security Classification

<u>Nomenclature</u>	<u>NSN</u>	<u>PN</u>	<u>CAGE</u>	<u>Qty</u>	<u>Classification</u>
Bolt together Wheel Kit consists of	2530-01-478-0958	57K4372	19207	1	Unclassified
Bolt together Wheel/Tire Assy	2610-01-477-1660	4SK793	45152	9	Unclassified
Plate, Instruction, MWO	9905-00-858-5682	10930014	19207	1	Unclassified

(2) Kit shipping Data: Weight 420 lbs.
Volume 26.7 cu.ft.

- b. Contents of MWO Kits: Refer to Table 4.
- c. Bulk and Expendable Material: None
- d. Parts Disposition: Contact TACOM, DSN 786-5869 or 786-8896 (Comm prefix 810-574-) for final disposition.

9. SPECIAL TOOLS; JIGS, TMDE AND FIXTURES REQUIRED

None.

10. MODIFICATION PROCEDURES

- a. Prepare Tire and Davit:
 - (1) Completely deflate spare tire, cut the valve stem and discard.

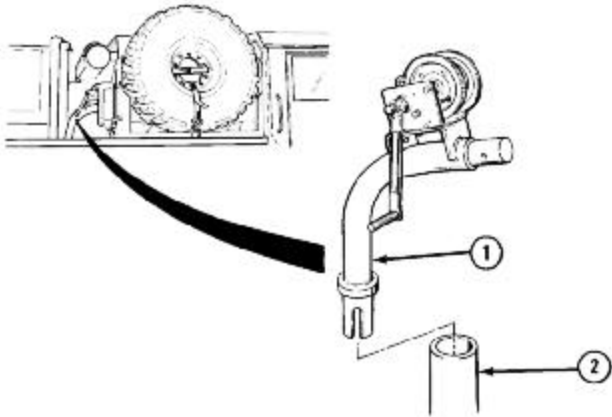

(2) Remove hoist arm (1) from mounting bracket (2).

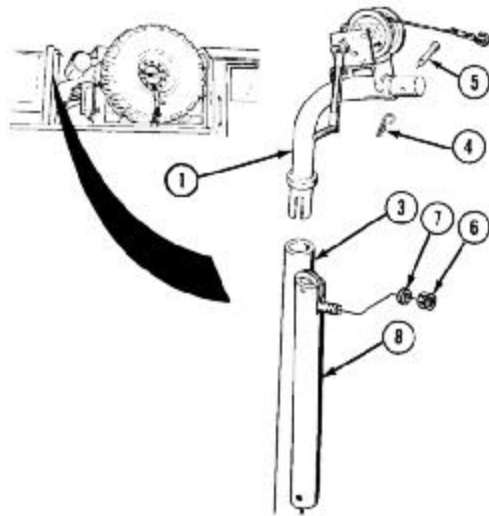

- (3) Install hoist arm (1) in Mount (3).
- (4) Remove and keep safety pin (4) and pin (5) from hoist arm (1).
- (5) Remove nut (6), Washer (7), and extension (8) from mount (3).

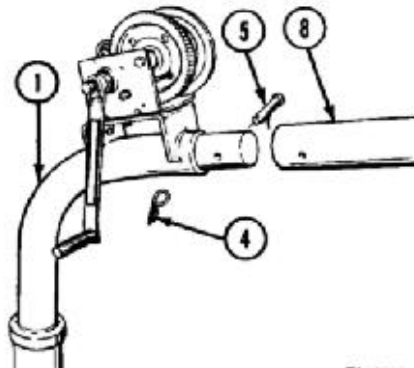

- (6) Install extension (8) on hoist arm (1).
- (7) Line up holes in extension (8) and hoist arm (1).
- (8) Install Pin (5) and safety pin (4).

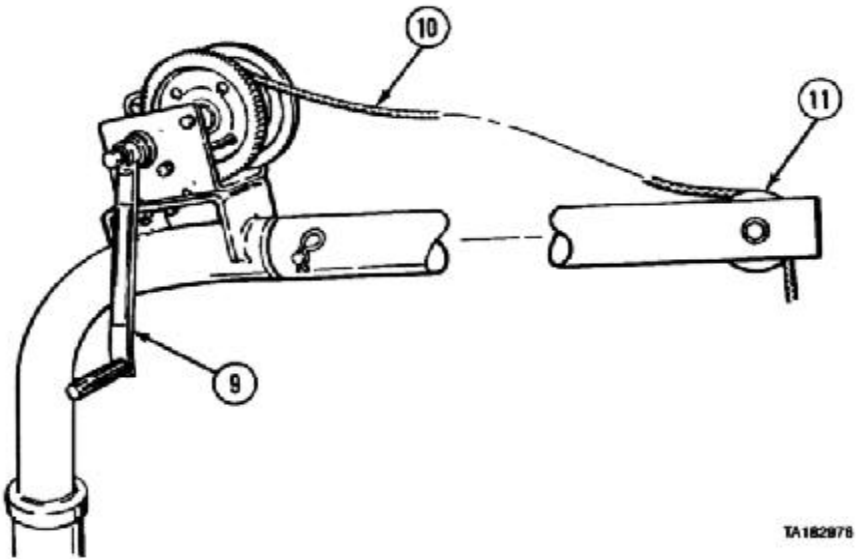

(9) Turn hand crank (9) counterclockwise and route cable (10) over end of pulley (11).

b. Remove Spare Tire.

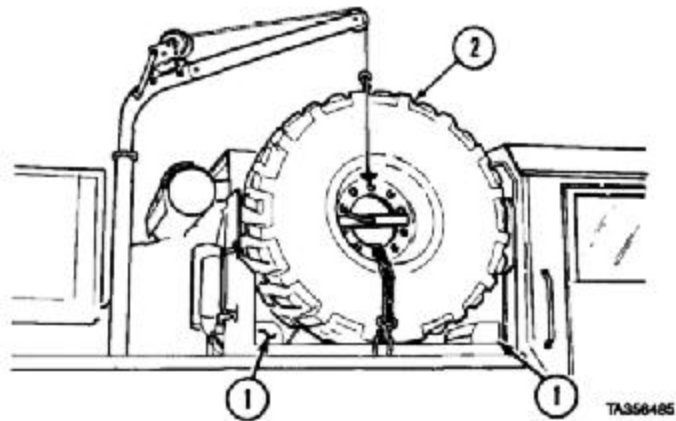

(1) Remove two chocks (1) from under spare tire (2).

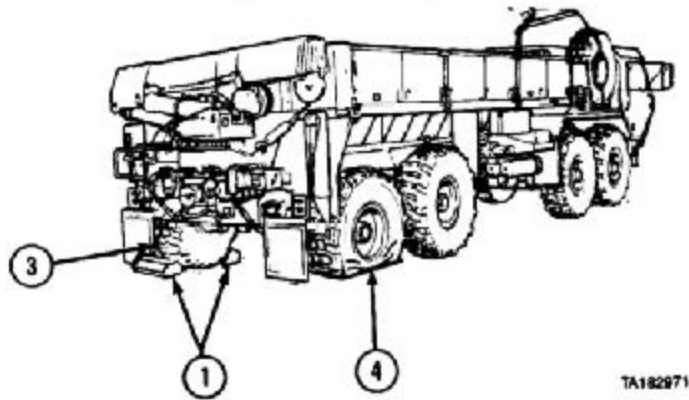

(2) Place two chocks (1) against tire (3) that is across from flat tire (4).

or any wheel/tire assembly that will be replaced. Move the chocks each time you replace a wheel/tire assembly and place them against the tire across from the wheel/tire assembly you are replacing.

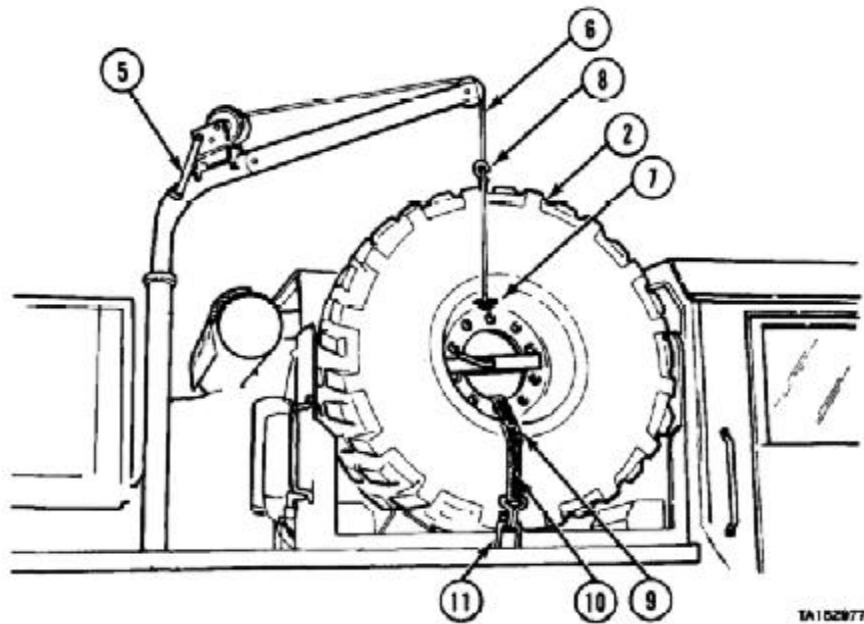

CAUTION

Never use slot that has valve stem or spare tire might be damaged.

- (3) Turn handcrank (5) counterclockwise to let out enough cable (6) to push through wheel (7) and wrap around spare tire (2).

NOTE

If spare tire is not mounted as shown, route cable through axle hole and dismount spare tire.

- (4) Wrap cable (6) around spare tire (2) and secure with hook (8).
 (5) Turn handcrank (5) clockwise to put light tension on cable (6).
 (6) Release clamp (9) and disconnect tiedown strap (10) from bracket (11) on both sides of spare tire (2).

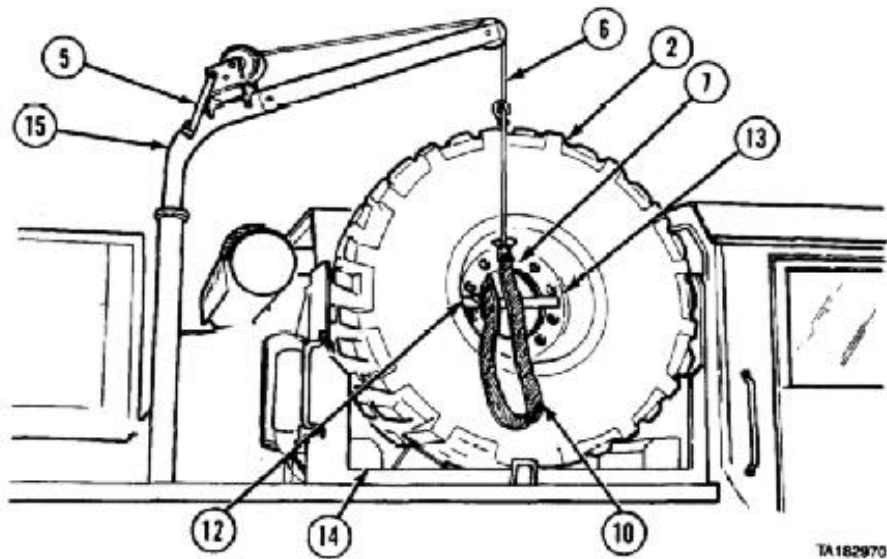

- (7) Hook tiedown strap (10) on hole in wheel (7) on both sides of spare tire (2).
- (8) Turn lever (12) counterclockwise.
- (9) Remove lever (12) and holddown plate (13). Keep lever and holddown plate for later use.

WARNING

Do not let tire hang in midair for long period of time. Place tire on carrier or on ground as soon as possible. Tire is very heavy and could cause serious injury if it falls.

NOTE

One Soldier stands on right fender to operate tire davit winch while other Soldier stands on ground near second axle to guide tire assembly down.

- (10) Turn handcrank (5) clockwise to lift spare tire (2) just above carrier (14).
- (11) Soldier A swings hoist arm (15) so spare tire (2) is clear of vehicle, while Soldier B pulls on tiedown strap (10) to guide spare tire out of carrier (14).
- (12) Soldier A turns handcrank (5) counterclockwise to lower spare tire (2) to ground while Soldier B holds spare tire steady with tiedown strap (10).
- (13) Remove tiedown strap (10).

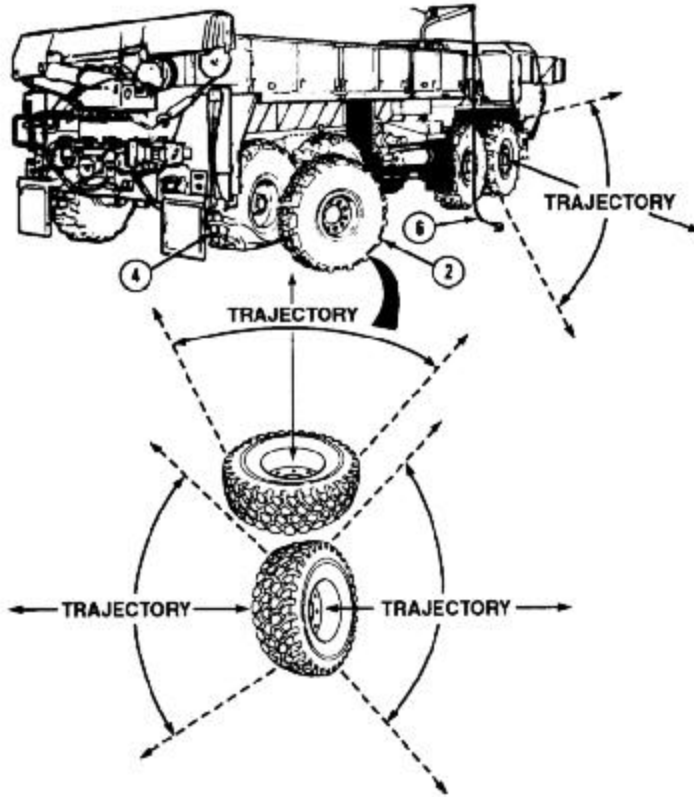

(14) Remove Cable (6) from spare tire (2). Roll spare wheel/tire assembly to maintenance facility for disposal in accordance with paragraph 10.h.

c. Remove split rim wheel/tire assembly from axle.

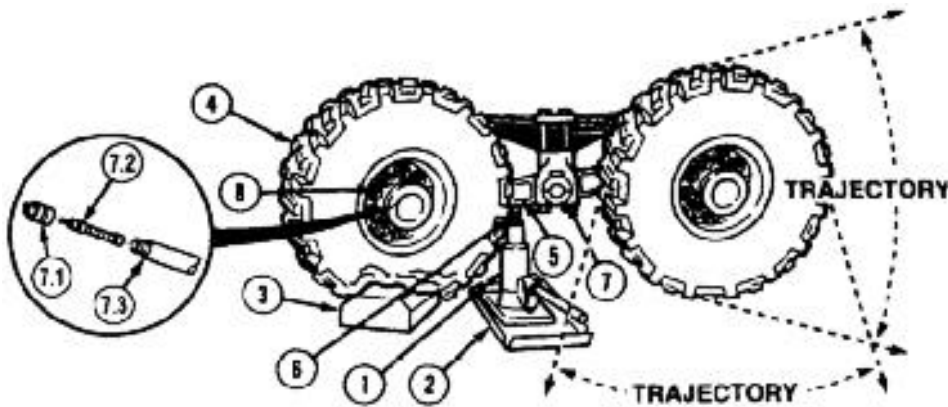

- (1) Remove jack (1) and jack base plate (2) from stowage.
- (2) If tire is flat, it may be necessary to place wheel chock (3) under flat tire (4) to get jack (1) under equalizer beam (5).
- (3) Position jack (1) and jack base plate (2) under equalizer beam (5).
- (4) Unscrew jack ram (6) until it touches equalizer beam (5) approximately 4 to 5 in. (102 to 127 mm) from beam center pivot point (7).

WARNING

- Tire must be completely deflated before trying to remove from vehicle, or serious injury or death could result.
- Stand clear of trajectory area during deflation or personal injury or death could result.
- Always completely deflate tire by removing valve core from valve stem before attempting removal operation. After air has finished exhausting from valve stem, carefully run a piece of wire through valve stem to ensure it is not plugged and tire is completely deflated. Failure to comply may result in injury to personnel.
- High air pressure may be released from valve stem when valve core is removed. Stay clear of valve stem after core is removed. Ensure all personnel wear suitable eye protection. Failure to comply may result in injury to personnel.

- (4.1) Tire must be completely deflated by removing valve cap (7.1) and valve core (7.2) until tire is completely deflated. When all air is removed, cut valve stem. Take wheel/tire assembly to unit maintenance for disposal in accordance with paragraph 10.h.

NOTE

Studs and lugnuts on left side of vehicle have left-hand threads. Rotate lugnuts clockwise to loosen, counterclockwise to tighten. Studs and lugnuts on right side of vehicle have right-hand threads. Rotate lugnuts counterclockwise to loosen, clockwise to tighten.

- (5) Loosen 10 lugnuts (8) until they turn easily.

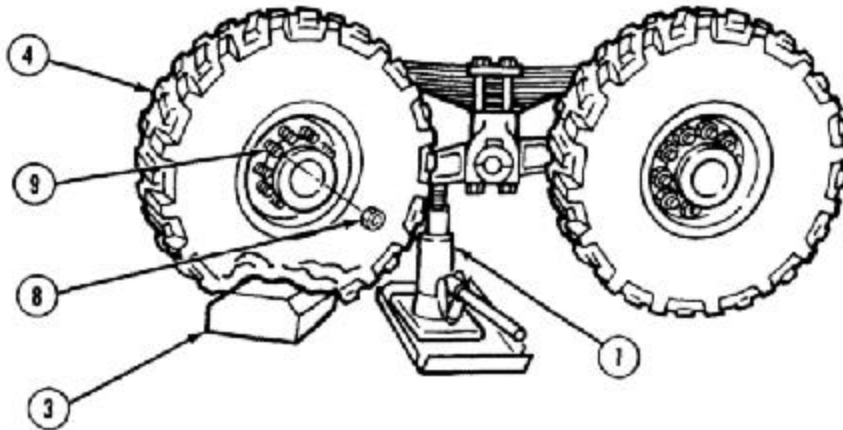

TA185074

NOTE

If chock was used to help position jack, tire does not have to be clear of chock.

- (6) Raise jack (1) until tire (4) can be removed.

WARNING

One Soldier should steady tire during removal. Falling tire may cause injury.

- (7) Remove 10 lugnuts (8) from studs (9). Set lugnuts aside.

NOTE

If wheel chock was not used to position jack, skip step (8).

- (8) Remove wheel chock (3) and put in stowage.

- (9) Using jack (1), lower vehicle until tire is just touching ground.
 (10) Soldier A tilts top of tire (4) forward, while soldier B raises jack (1) slightly. Tire should move forward.
 (11) Repeat steps (9) and (10) to walk tire (4) off studs (9).
 (12) Remove wheel/tire assembly (4) roll wheel/tire assembly to maintenance shop for disposal in accordance with paragraph 10.h.

d. Inflate New Wheel Tire Assemblies

WARNING

Failure to comply with these procedures may result in faulty positioning of the tire and/or rim parts, and cause the assembly to burst with explosive force, sufficient to cause serious physical injury or death. Never mount or use damaged tires or rims.

NOTE

There are two types of air pressure gages. Model A is a separate hand held gage used on vehicle serial number 51130 and below. Model B is a combined pressure gage/inflation hose used on vehicle serial number 51131 and above.

- (1) Check tire air pressure with tire pressure gage.
- (2) Use table to make sure tires have correct air pressure for road conditions and driving speed.

Tire Pressure

	<u>Highway</u>	<u>Cross Country-dry</u>	<u>Cross Country-Wet</u>	<u>Sandy Terrain</u>
Front (all models)	60 psi	35 psi	20 psi	30 psi
Rear M977, M978, M983	70 psi	40 psi	30 psi	35 psi
M984A1	100 psi	100 psi	100 psi	30 psi
M985	90 psi	50 psi	40 psi	40 psi
Spare tire (All Models)	100 psi	100 psi	100 psi	100 psi

e. Install Spare Tire/Wheel

NOTE

- Tire tread is non-directional. Vehicle operation is not affected by direction of traction bars.
- Some hubs have three bosses added during manufacture that can interfere with installation of bolt together wheels. If replacing a split rim wheel, inspect hub for any bosses that might interfere with installation of the bolt together wheel.
- Axles no. 1 and no. 2 on all vehicles and all axles on M984A1 are not affected.
- On rear tandem axles of all models, except M984A1, the brake drum may have a boss of different widths or the same width.
- If the width of the two bosses on the drum are different, no rework is required. If all the bosses are the same size, then the bosses must be removed.

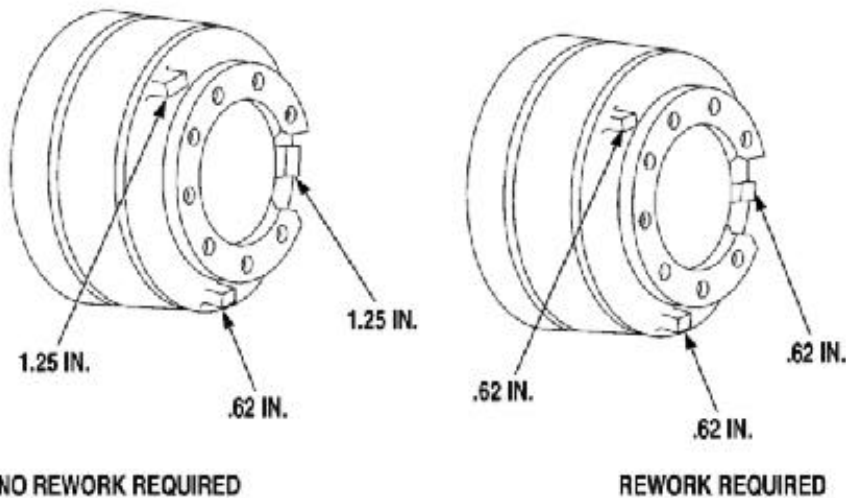

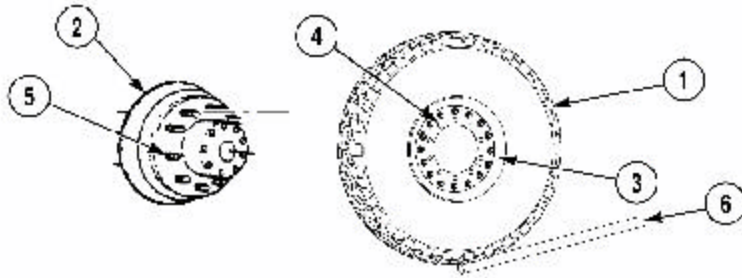

- (1) Roll replacement wheel/tire assembly (1) up to axle (2) where split rim wheel/tire assembly was removed.

NOTE

Check that replacement wheel dish is in same position as previous tire wheel dish. Deep side of wheel dish will face toward vehicle on four front wheels. Deep side of wheel dish will face away from vehicle on four wheel vehicles except M984A1. All eight wheels on M984A1 are installed with deep side of dish facing toward vehicle.

- (2) Make sure deep side of replacement tire wheel dish (3) is in same position as split rim tire wheel dish when split rim wheel tire was removed.

- (3) Make sure tire valve stem extension is pointing out away from vehicle.

WARNING

Tire assembly is very heavy. Do not try to lift or catch tire assembly. Injury to personnel could result.

- (4) Line up holes (4) in replacement tire (1) with studs (5).
- (5) Lean top of replacement tire (1) against studs (5) and axle (2).
- (6) Using handle extension (6), Soldier A slides replacement tire onto studs (5) while Soldier B raises vehicle with jack. Bottom of replacement tire should swing toward vehicle.
- (7) Lower vehicle with jack until replacement tire (1) just touches ground
- (8) Repeat steps (5) through (7) until replacement tire (1) is seated on axle (2) and studs (5).

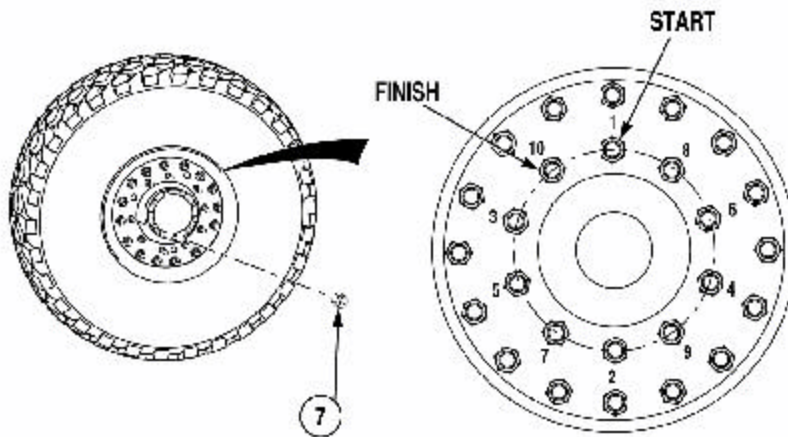

NOTE

Studs and lugnuts on left side of vehicle have left-hand threads. Rotate lugnuts clockwise to loosen, counterclockwise to tighten. Studs and lugnuts on right side of vehicle have right-hand threads. Rotate lugnuts counterclockwise to loosen, clockwise to tighten.

- (9) Install and tighten 10 lugnuts (7) using wheel lugnut wrench to tighten in order shown.

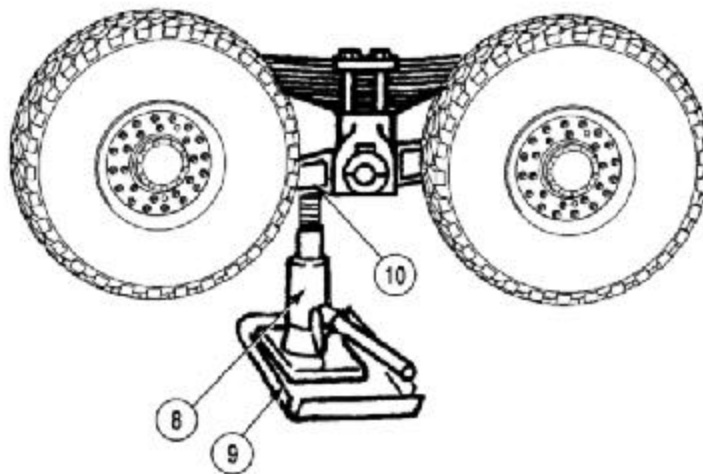

- (10) Use jack (8) to lower vehicle to ground.
- (11) Remove jack (8) and jack base plate (9) from under equalizer beam (10).

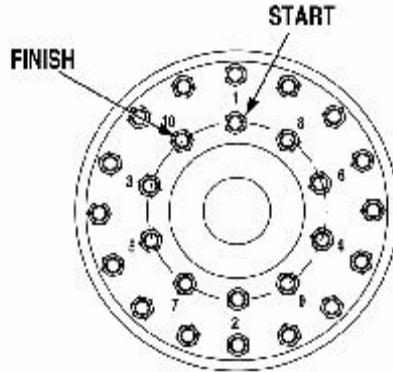

(12) Tighten 10 lugnuts (7) in order shown until they no longer tighten.

(13) Tighten 10 lugnuts (7) to correct torque value.

Front Wheels	Rear Wheels Except M984A1	Rear Wheels M984A1
575-625 lb-ft (780-848 N-m)	450-500 lb-ft (610-678 N-m)	575-625 lb-ft (780-848 N-m)

(14) Repeat procedure for all wheel/tire assemblies

f. Install New Spare

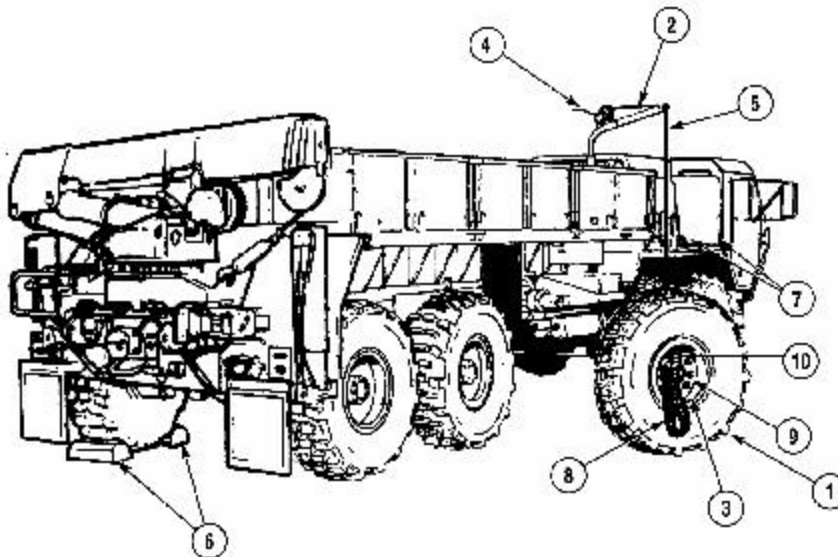

(1) Roll replacement spare tire (1) under hoist arm (2) so deep side of dish (3) is facing out and away from vehicle.

NOTE

One soldier stands on right front fender to operate tire davit winch while other Soldier stands on ground near second axle to guide tire assembly into carrier.

- (2) Turn handcrank (4) counterclockwise to let out cable (5).
- (3) Remove two wheel chocks (6).
- (4) Stow wheel chocks (6) on carrier (7).
- (5) Pull tiedown strap (8) through wheel (9) and hook ends to hole (10) on both sides of wheel.

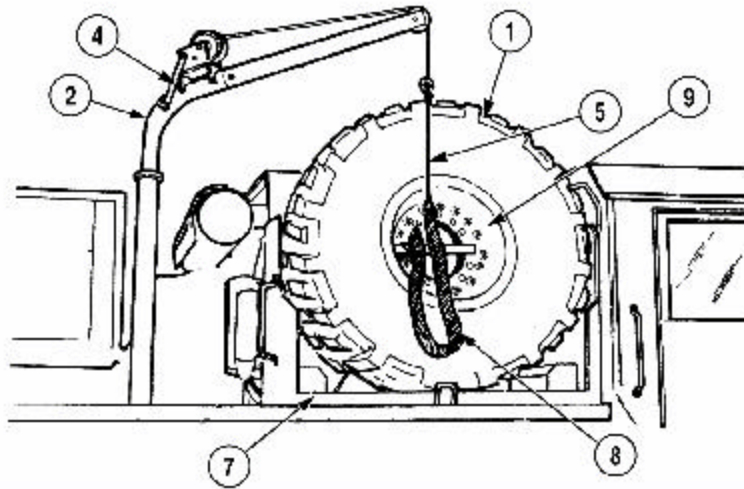

- (6) Pull cable (5) through wheel (9) and hook to top of cable.

WARNING

Do not let tire hang in midair for long period of time. Place tire on carrier or ground as soon as possible. Tire is very heavy and could seriously injure personnel if it falls.

- (7) Soldier A turns handcrank (4) clockwise to raise spare tire (1) just above carrier (7) while soldier B guides tire with tiedown strap (8).
- (8) Soldier A swings hoist arm (2) so that tire is over carrier (7) while soldier B guides tire with tiedown strap (8).
- (9) Turn handcrank (4) counterclockwise to lower spare tire (1) into carrier (7).
- (10) Remove tiedown strap (8).

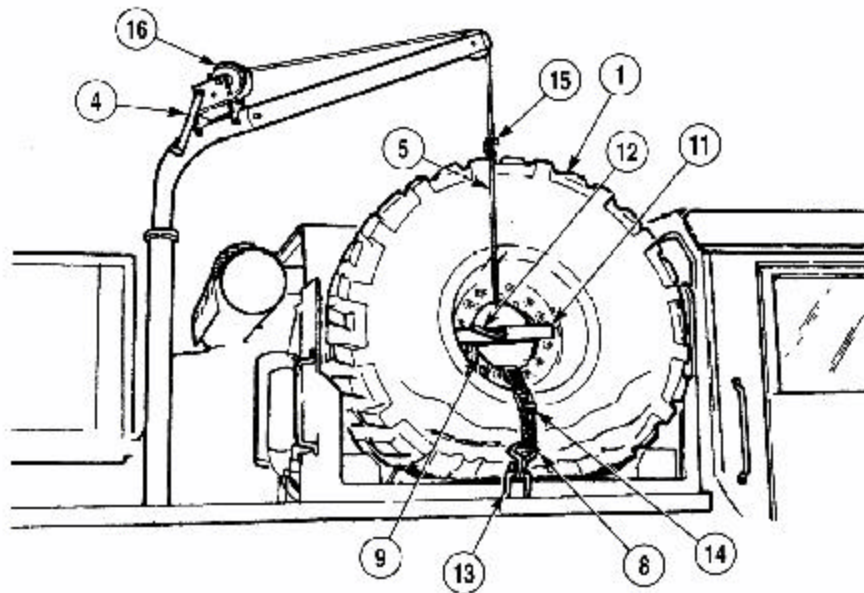

- (11) Soldier A connects tiedown strap (8) to outside holddown bracket (13), while soldier B connects tiedown strap to inside holddown bracket.
- (12) Soldier A holds spare tire (1) steady, while soldier B installs holddown plate (11).
- (13) Install lever (12) and turn clockwise to tighten.
- (14) Slide tiedown strap (8) through wheel (9).
- (15) Pull latch (14) down and lock to secure spare tire (1).
- (16) Turn handcrank (4) counterclockwise to loosen cable (5).
- (17) Remove hook (15) and cable (5) from wheel/tire assembly (9).
- (18) Turn handcrank (4) clockwise and wind cable (5) onto reel (16).

g. Stow Tire Davit Winch

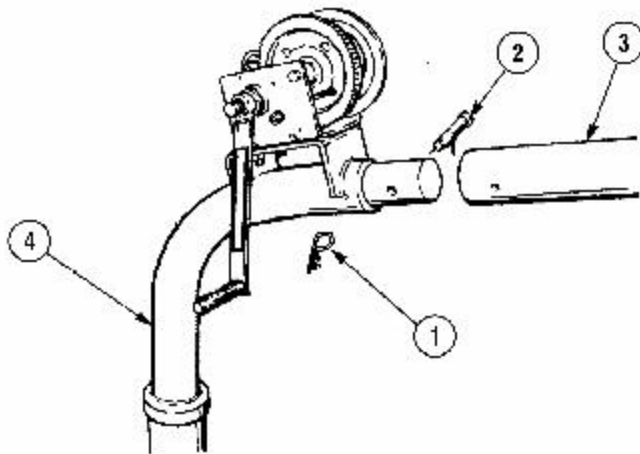

NOTE

On M983 with crane, tire davit winch is located on extension, not on hoist arm.

- (1) Remove safety pin (1) and pin (2) from extension (3).
- (2) Pull extension (3) from hoist arm (4).

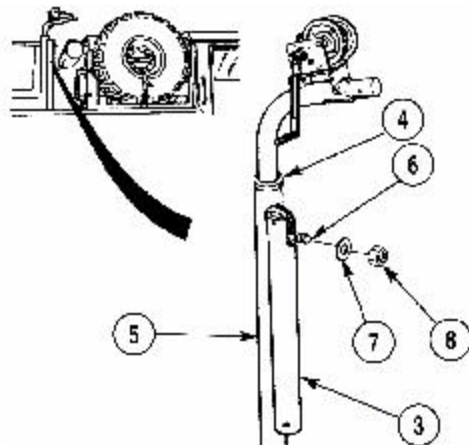

- (3) Install extension (3) on mount (5).
- (4) Slide top of extension over studs (6).
- (5) Secure extension (3) with washer (7) and nut (8).
- (6) Pull hoist arm (4) from mount (5).

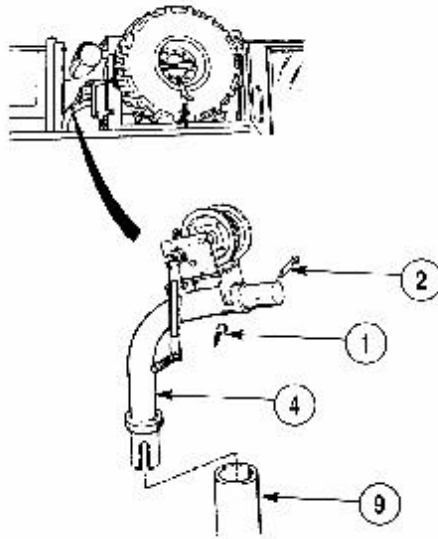

- (7) Put hoist arm (4) into mounting bracket (9).
- (8) Install pin (2) through hoist arm (4).
- (9) Secure pin (2) with safety pin (1).
- (10) Pick up and stow emergency marker kit (para 2-44).

h. Steering System adjustments

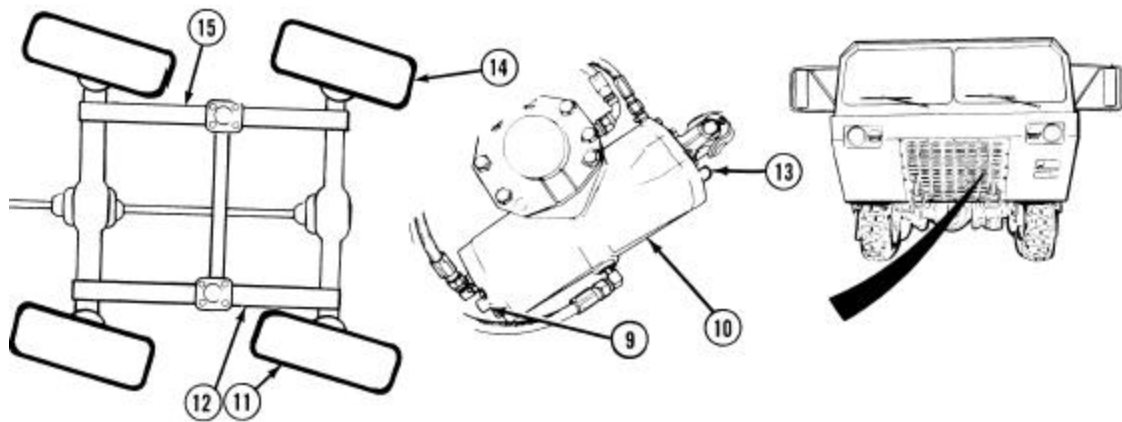

NOTE

If you change from Michelin XL or Goodyear AT2A tires, NSN 2610-01-126-1576, to Michelin XZL tires, NSN 2610-01-334-2694, your steering system will need adjustment.

You can have your Direct Support shop adjust your steering or follow the instructions in steps (13) thru (17).

Axle stop bolts should be turned in to prevent interference with relief plunger adjustment

Turning plunger counter-clockwise will decrease gap between equalizer beam and tire turning clockwise will increase gap.

Each time relief plunger is adjusted, wheels must be turned toward center and then back to stops to obtain full steering relief. Plunger on bottom of steering gear regulates right turns and plunger on top regulates left turns.

- (13) Soldier A adjusts plunger (9) on steering gear (10) to obtain 1 in. (25.4 mm) clearance between tire (11) and equalizer beam (12).
- (14) Soldier A adjusts plunger (13) on steering gear (10) to obtain 1 in. (25.4 mm) clearance between tire (14) and equalizer beam (15).
- (15) Turn wheels all the way to the right.
- (16) Set 1/8-in. (3 mm) gap between stop bolt (16) and ball (17) on left end of axle No. 2 and right end of axle No. 1 by loosening nut (18) and turning stop bolt.
- (17) Tighten nut (18) on both axles.
- (18) Turn wheels all the way to the left.
- (19) Set 1/8-in. (3 mm) gap between stop bolt (16) and ball (17) on right end of axle No. 2 and left end of axle No. 1 by loosening nut (18) and turning stop bolt.
- (20) Tighten nut (18) on both axles.

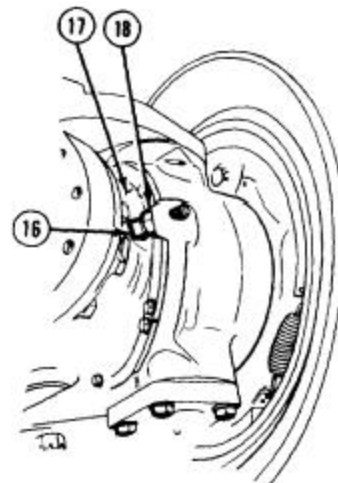

i. Break Down Wheels

NOTE

Contact TACOM, DSN 786-5869, 786-8896 (Comm. prefix 810-574-) for final disposition instructions prior to breaking down the wheels, demil and disposition IAW section 10.h.

a. Disassembly.

WARNING

- Wheel/tire assembly weighs 540 lbs (245 kg). Use suitable lifting device to lift wheel/tire assembly and prevent possible injury to personnel.
- Wheel/tire must be deflated in a safety cage or personal injury or death may result.

NOTE

Refer to TM 9-2610-200-14 for construction of safety cage.

- (1) Using lifting device, position wheel/tire assembly (1) in a safety cage.
- (2) Remove cap (2) from valve stem (3).

WARNING

- Always completely deflate tire by removing valve core from valve stem before attempting demounting operation. After air has finished exhausting from valve stem, carefully run a piece of wire through valve stem to ensure it is not plugged and tire is completely deflated. Failure to comply may result in injury to personnel.
- High air pressure may be released from valve stem when valve core is removed. Stay clear of valve stem after core is removed. Ensure all personnel wear suitable eye protection. Failure to comply may result in injury to personnel.
- Stand clear of trajectory area during deflation, or personal injury or death may result.

- (3) Using valve core inserter and remover, remove valve core (4) from valve stem (3) and completely deflate tire (5). Discard valve core.

(3) Tire should have been deflated prior to removal from vehicle. To assure deflation prior to disassembly, cut the valve stem valve off the tire and discard the valve stem.

(4) Remove wheel/tire assembly (1) from safety cage and position on wooden stand with lockring (6) facing up.

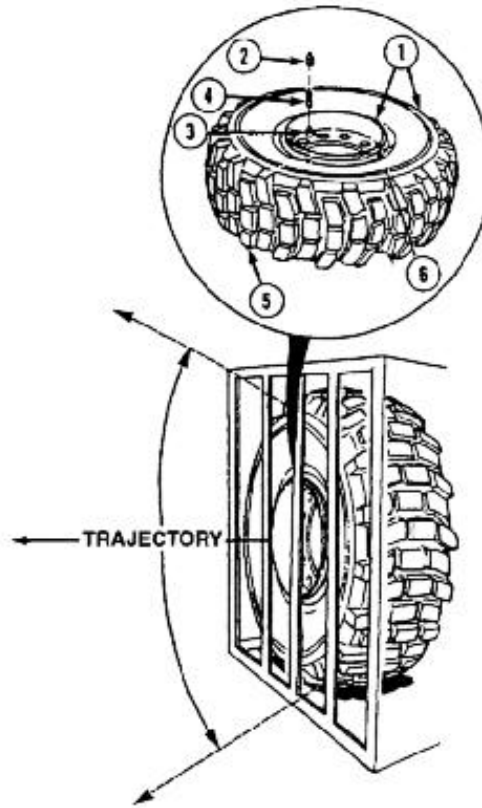

- (5) Insert the goose-necked end of two tire irons between tire (5) and side ring (7) approximately 5 in. (13 cm) apart.

CAUTION

- Ensure not to tear the chafer fabric when unseating the tire bead or damage to tire may result.
 - Use tire lubricant as necessary to avoid damaging tire beads or bead seats during demounting.
- (6) Pry both tire irons outward and sideways through an arc of about 70 degrees. Leave one tire iron in position and place the second tire iron approximately 5 in. (13 cm) away. Repeat this procedure until tire bead (8) is completely unseated.

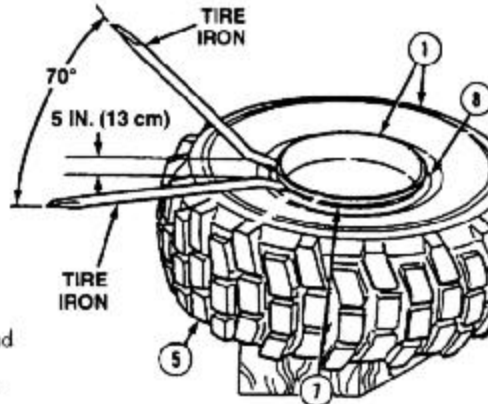

WARNING

Lockring is under tension. If lockring breaks loose it could cause injury to personnel. Keep hands and fingers away from lockring when removing.

NOTE

Ensure side ring and tire side wall are depressed below lockring.

- (7) Insert tire iron in tool notch in lockring (6) and pry lockring outward while using second tire iron to pry lockring upward, then using first tire iron next to second tire iron to pry lockring upward, continue around lockring until it is fully removed from lockring groove (9) in wheel (10).
- (8) Remove side ring (7) from tire (5) and wheel (10). Use tire irons if necessary.
- (9) Reserved.

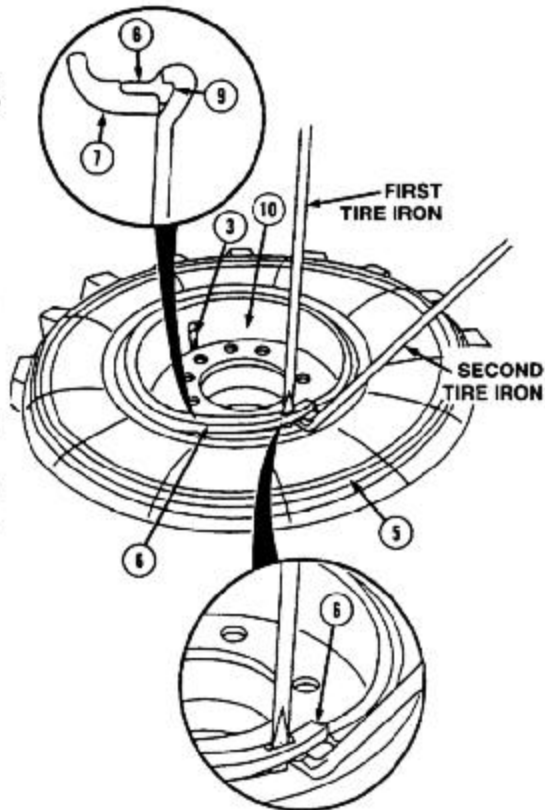

WARNING

Wheel/tire assembly weighs 540 lbs (245 kg). Use suitable lifting device to lift wheel/tire assembly and prevent possible injury to personnel.

- (10) Using lifting device, turn wheel/tire assembly (1) over on block so flange is facing up.
- (11) Repeat steps (5) and (6) to unseat tire bead (8) from wheel/tire assembly (1).

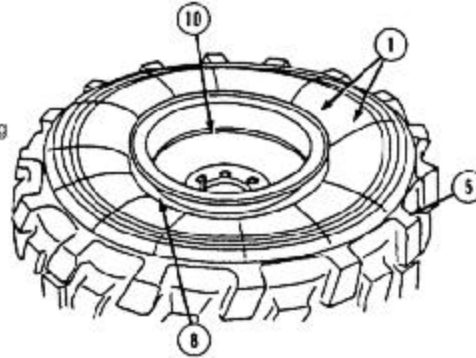

WARNING

Wheel weighs 110 lbs (50 kg). Use suitable lifting device to lift wheel to prevent possible injury to personnel.

- (12) Using lifting device, remove wheel (10) from tire (5).
- (13) Remove wooden stand from tire (5).

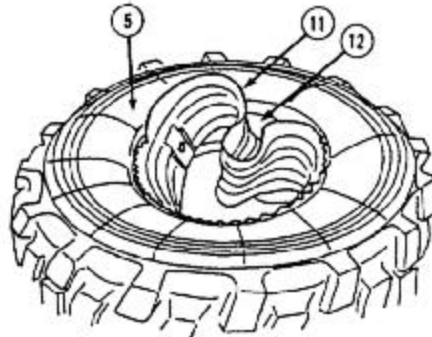

CAUTION

When removing flap from tire be careful not to damage valve stem.

- (14) Remove flap (11) from tire (5).
- (15) Remove inner tube (12) from tire (5).
- (16) Drill a 1 inch hole through the side of any Michelin XL tire. If the tire is a Goodyear AT2A or Michelin XZL, inspect in accordance with TM 9-2320-279-20-1 or TM 9-2610-200-14. Serviceable tires can be retained and unserviceable tires should be sent to the local DRMO.
- (17) Destroy the split rings, side rings and rims by cutting them into 2 pieces to prevent future use. Send pieces to DRMO.

11. CALIBRATION REQUIREMENTS. Not applicable.

12. WEIGHT AND BALANCE DATA: Weight and Balance are not significantly affected

13. QUALITY ASSURANCE REQUIREMENTS. Not Applicable

14. RECORDING AND REPORTING OF THE MODIFICATION.

A. Records and Reports: The organization responsible for MWO application will report application information as follows:

(1) Reporting will be accomplished by electronic means. MWO application information can be input directly in the Modification Management Information System (MMIS) over the Internet. If Internet is not available, recording will be on a 3.5 inch disk, which will be mailed to the MMIS administrator. Entry into the MMIS system is password protected. New users can register on-line at <http://65.196.121.253/mwo>. Passwords are normally approved and issued within 48 hours.

(2) Submission will be comprised of the nine (9) data elements listed in the Table below. Elements 1, 2, 8 & 9 are given for this MWO (as shown). The person reporting the MWO data, will acquire the remaining elements 3, 4, 5, 6, 7 and input all nine into MMIS.

<u>DATA ELEMENT</u>	<u>INPUT DATA</u>
1. Materiel Change Number MCN	1-00-06-0003
2. MWO Number	MWO 9-2302-279-20-9
3. Unit Identifier Code	
4. NSN of the End Item	
5. Serial Number	
6. USA Registration Number	
7. Date of Application	
8. Hours Required for Application	
9. Software Version	N/A

(3) For off-line reporting, the 3.5 inch disk shall be mailed to the following address:

Commander
 US Army Tank- Automotive and Armaments Command
 ATTN: AMSTA-LC-CIPWM (Leanne Filary)
 Warren, MI 48397-5000

(4) Marking Equipment

- (a) After wheel/tire assemblies have been changed, mark MWO number in the MWO Applied Block and date applied in Date Block on MWO Instruction plate 10930014.
- (b) Install 10930014 MWO instruction plate by drilling a 0.104-inch diameter hole on driver side door next to the tire inflation data decal and secure with MS21318-20 drive screw .
- (c) After drive screw is installed, flatten or remove protruding excess drive screw material from inside of door pane,.

15 MATERIAL CHANGE NUMBER. This MWO is Authorized by Material Change number 1-00-06-0003.

16. MODIFICATION IDENTIFICATION. The bolt-together wheels have 16 studs in addition to the wheel mounting studs in a ring around the wheel. An MWO instruction plate will be placed on the inside of the driver side door.

By Order of the Secretary of the Army:

Official:



JOEL B. HUDSON

*Administrative Assistant to the
Secretary of the Army*

0124201

ERIC K. SHINSEKI
*General, United States Army
Chief of Staff*

DISTRIBUTION: To be distributed in accordance with the initial distribution requirements for IDN: 381110, MWO 9-2320-279-20-9.

RECOMMENDED CHANGES TO EQUIPMENT TECHNICAL PUBLICATIONS



THEN...JOT DOWN THE
DOPE ABOUT IT ON THIS FORM.
CAREFULLY TEAR IT OUT, FOLD IT
AND DROP IT IN THE MAIL.

SOMETHING WRONG WITH PUBLICATION

FROM: (PRINT YOUR UNIT'S COMPLETE ADDRESS)

DATE SENT

PUBLICATION NUMBER

PUBLICATION DATE

PUBLICATION TITLE

BE EXACT PIN-POINT WHERE IT IS

PAGE
NO.

PARA-
GRAPH

FIGURE
NO.

TABLE
NO.

IN THIS SPACE, TELL WHAT IS WRONG
AND WHAT SHOULD BE DONE ABOUT IT.

TEAR ALONG PERFORATED LINE

PRINTED NAME, GRADE OR TITLE AND TELEPHONE NUMBER

SIGN HERE

THE METRIC SYSTEM AND EQUIVALENTS

WEIGHT MEASURE

1 Centimeter = 10 Millimeters = 0.01 Meters = 0.3937 Inches
 1 Meter = 100 Centimeters = 1000 Millimeters = 39.37 Inches
 1 Kilometer = 1000 Meters = 0.621 Miles

WEIGHTS

1 Gram = 0.001 Kilograms = 1000 Milligrams = 0.035 Ounces
 1 Kilogram = 1000 Grams = 2.2 lb.
 1 Metric Ton = 1000 Kilograms = 1 Megagram = 1.1 Short Tons

LIQUID MEASURE

1 Milliliter = 0.001 Liters = 0.0338 Fluid Ounces
 1 Liter = 1000 Milliliters = 33.82 Fluid Ounces

SQUARE MEASURE

1 Sq. Centimeter = 100 Sq. Millimeters = 0.155 Sq. Inches
 1 Sq. Meter = 10,000 Sq. Centimeters = 10.76 Sq. Feet
 1 Sq. Kilometer = 1,000,000 Sq. Meters = 0.386 Sq. Miles

CUBIC MEASURE

1 Cu. Centimeter = 1000 Cu. Millimeters = 0.06 Cu. Inches
 1 Cu. Meter = 1,000,000 Cu. Centimeters = 35.31 Cu. Feet

TEMPERATURE

$5/9(^{\circ}\text{F} - 32) = ^{\circ}\text{C}$
 212° Fahrenheit is equivalent to 100° Celsius
 90° Fahrenheit is equivalent to 32.2° Celsius
 32° Fahrenheit is equivalent to 0° Celsius
 $9/5^{\circ}\text{C} + 32 = ^{\circ}\text{F}$

APPROXIMATE CONVERSION FACTORS

TO CHANGE	TO	MULTIPLY BY
Inches	Centimeters	2.540
Feet	Meters	0.305
Yards	Meters	0.914
Miles	Kilometers	1.609
Square Inches	Square Centimeters	6.451
Square Feet	Square Meters	0.093
Square Yards	Square Meters	0.836
Square Miles	Square Kilometers	2.590
Acres	Square Hectometers	0.405
Cubic Feet	Cubic Meters	0.028
Cubic Yards	Cubic Meters	0.765
Fluid Ounces	Milliliters	29.573
its	Liters	0.473
arts	Liters	0.946
allons	Liters	3.785
Ounces	Grams	28.349
Pounds	Kilograms	0.454
Short Tons	Metric Tons	0.907
Pound-Feet	Newton-Meters	1.356
Pounds per Square Inch	Kilopascals	6.895
Miles per Gallon	Kilometers per Liter	0.425
Miles per Hour	Kilometers per Hour	1.609

TO CHANGE	TO	MULTIPLY BY
Centimeters	Inches	0.394
Meters	Feet	3.280
Meters	Yards	1.094
Kilometers	Miles	0.621
Square Centimeters	Square Inches	0.155
Square Meters	Square Feet	10.764
Square Meters	Square Yards	1.196
Square Kilometers	Square Miles	0.386
Square Hectometers	Acres	2.471
Cubic Meters	Cubic Feet	35.315
Cubic Meters	Cubic Yards	1.308
Milliliters	Fluid Ounces	0.034
Liters	Pints	2.113
Liters	Quarts	1.057
ers	Gallons	0.264
ms	Ounces	0.035
ograms	Pounds	2.205
Metric Tons	Short Tons	1.102
Newton-Meters	Pounds-Feet	0.738
Kilopascals	Pounds per Square Inch	0.145
ometers per Liter	Miles per Gallon	2.354
ometers per Hour	Miles per Hour	0.621



PIN: 079256-000